



Received: 20 March, 2023

Accepted: 31 March, 2023

Published: 01 April, 2023

\*Corresponding authors: Dr. Muhittin Yağmur Polat, PhD, Soil, Fertilizer and Water Resources Central Research Institute, Ankara, Turkey, Tel: +90 505 726 07 19; E-mail: yagmur.polat@tarimorman.gov.tr

ORCID: <https://orcid.org/0000-0003-2795-4798>

Keywords: Mole drainage; Mole drain plows; Subsoiler

Copyright License: © 2023 Polat MY, et al. This is an open-access article distributed under the terms of the Creative Commons Attribution License, which permits unrestricted use, distribution, and reproduction in any medium, provided the original author and source are credited.

<https://www.peertechzpublications.com>



Check for updates

## Mini Review

# A brief overview to give a new perspective on mole drainage

Muhittin Yağmur Polat<sup>1\*</sup> and Mehmet Emin Bilgili<sup>2</sup>

<sup>1</sup>Soil, Fertilizer and Water Resources Central Research Institute, Ankara, Turkey

<sup>2</sup>Eastern Mediterranean Agricultural Research Institute, Adana, Turkey

## Abstract

Draining excess water from the soil is the general purpose of drainage. Thus, soil protection is provided and product losses are prevented. Mole drainage consists of underground galleries that act as piped drainage. This type of drainage is mostly used successfully in clay, organic, and highly cohesive soils. It is used successfully in areas with high groundwater, during the improvement of salty and sodium soils. The biggest benefit of mole drainage is cheap and economical. In the mole drainage method, tunnels are opened under the tillage depth with a torpedo-shaped piece at the end of a foot extending under the soil. These tunnels are called mole drains. In the mole drainage method, the channels are built with mole drain plows and subsoilers. In order to benefit more effectively from mole drainages, parameters such as suitable working width, working depth and slope must be finely adjusted. For this, modern alternatives such as GPS and laser positioning systems can be used.

## Introduction

### Drainage in agriculture

The processes carried out to remove excess water from the soil surface and plant root zone are called drainage. With good drainage, an airy root zone, dry topsoil for tillage and suitable soil conditions for plant growth are provided [1].

The general purpose of drainage is to prevent crop reductions caused by excess water in agricultural production areas and to provide better crops. Excess water may be on the soil surface, in the root zone, or both. In order to obtain a good crop, proper soil-water-air and the salt balance must be established in the soils [2].

In agricultural terms, the aims of drainage can be listed as increasing vegetative production, maintaining productivity, washing salty and barren lands to save them from barrenness, drying swampy lands and adding them to agricultural production, prolonging the growing period of plants to obtain maximum efficiency and correcting the structure of the soil.

The successful operation of the irrigated areas and irrigation projects does not only depend on the supply of irrigation water and the application of the selected irrigation systems but also on the control of soil moisture and salinity. This can only be achieved by drainage. The process of removing the excess water in the soil from that area by means of drain pipes or drain channels through the soil profile is called closed or subsoil drainage [1].

### Mole drainage

Especially in soils with low hydraulic conductivity ( $k < 0.01 \text{ m day}^{-1}$ ), heavy clay or clay textured soils with low permeability, drains should be run very frequently (2 m – 4 m) in order to control the groundwater level at an appropriate depth. In these conditions, piped drainage systems are not economical. Therefore, different techniques must be used. A closed drainage type that works well in this type of soil is mole drainage. It consists of underground galleries that act as piped drainage. This type of drainage is mostly used successfully in clay, clay-loam, organic, highly cohesive, or fibrous soils. It is used successfully in areas with perched groundwater, during

the improvement of salty and sodium soils as well as paddy fields with groundwater problems. It is inefficient to work with this system on loamy soils, sandy soils, stony lands, or similar handicapped areas [1,3,4].

The biggest benefit of the mole drainage method is that it is cheap and therefore mole drains can be easily prepared at close distances economically. The most important factor limiting the method is the short drain life. If the drains are opened correctly, they can be used for 1 - 7 years. But even with short service times, they are economically beneficial. The success of the mole drainage method depends on preserving the structure of the drains and keeping the drains open for a reasonable period of time. Their activity decreases over time due to sediment filling [1,4,5].

In the mole drainage method, tunnels are opened under the tillage depth with a torpedo-shaped piece at the end of a foot extending under the soil. These tunnels are called mole drains (Figure 1). These drainage channels, which are opened with oval or circular cross-sections, function like drainage pipes placed under the ground, especially in heavy textured soils [6].

In the mole drainage method, the channels are built with mole drain plows (Figure 2) and subsoilers. Mole drain plows consist of a working piece in the form of a torpedo or narrow tip iron attached to a fixed foot that splits the soil and a cylindrical expander usually connected to this piece with a chain [4,7].

The diameter of mole drains can be 5 cm - 10 cm, and 15 cm in organic soils. While the mole drain channels are opened, the working depths of the machines are between 40 cm - 50 cm for grasslands-rangelands and 50 cm - 60 cm for arable fields. The intervals between the mole drains vary between 4 m - 10 m, the drain lengths vary between 60 m - 70 m depending on the slope, and the slope varies between 0.6% - 1%. In more than 55% clay soils, it is desirable that the intervals between the drain channels exceed 4 m. Mole drains can also be drawn perpendicular to the main drainage channels. With mole drain plows, drains can be opened on an area of 5 - 10 ha per day at a speed of 5 km h<sup>-1</sup>. Tractors with high drawbar power are used to implement the mole drainage method. With a mole drain plow with a 75 mm diameter torpedo, approximately 25 kN drawbar force is required for the work to be carried out at a working depth of 50 cm [1,4,7,8].

Mole drain channels can also be opened with a 5 cm - 7.5 cm diameter torpedo attached subsoiler behind the feet (Figure 3). Thanks to the torpedo, cylindrical drain channels are formed in the soil. If the application with the subsoiler is applied perpendicular to the main drainage lines, in addition to evacuating excess water, additional water discharge is provided thanks to the effect of the subsoiler [1,4,8-10]. A subsoiler prepared for the mole drainage method is connected to the tractor from a three-point linkage system and used at a working depth of approximately 70 cm. The tip of the subsoiler is located in the front of the torpedo; it has a pointed-rounded or forward-curved-flat working tip. The ones with a round base have a base diameter of 40 mm - 100 mm. The power demand of the machine is around 45 kW [8].



Figure 1: Example of a mole drain [6].



Figure 2: Mole drain plow [17].



Figure 3: A subsoiler that can open a mole drain.  
Sources: Muhittin Yağmur Polat, 2023.

In mole drainage, during the opening of the channel, the soils are pushed to the sides where the mole plow and expander pass. As the foot advances, it creates crevices and cracks that increase the porosity and hydraulic conductivity of the soil (Figure 4). The angle of these crevices and cracks is about 45°



with the horizontal. If these crevices and cracks combine with the mole canal, they cause it to deteriorate quickly. In this regard, the mole drain should be laid under these cracks. This depth under the cracks is called critical depth. Sometimes these crevices and cracks are not formed enough. In this case, a blade in the form of a wing (Figure 5) is attached to the middle part of the foot of the mole drain plow, whose surface is parallel to the ground and whose thickness increases towards the back [4,7].

In the mole drainage method, the drain structures can easily deteriorate for various reasons. The rate of this deterioration process affects the useful life of mole drains. The life of these drains is the stability of the soil, the soil moisture conditions during the laying of the drains, the methods and equipment used in the installation of the drains, the diameter of the drain, the water flow rates in the drains, the amount and intensity of precipitation, the long-term submersion of the drains, seasonal temperature changes and the depth of the drain [4].

Mole drainage performance is known to vary temporally and spatially due to changes in soil properties, installation conditions, mole channel integrity and weather patterns. In fine-textured, low-permeability soil profiles, moles can be placed to support an underlying tile drainage system. However, moles are not usually included in such designs [11].

A simple test can be helpful in deciding whether soils are suitable for mole drainage. After the soil sample is formed into

a ball with a diameter of 7 cm – 8 cm, it is placed in a container filled with water and left to itself for 12 – 14 hours. If there is no deterioration in the sample at the end of this period, it is concluded that the soil is suitable for a mole drain plant. The degree of deterioration of the soil sample will give an idea of the probability of success of the mole drainage method in the soil in question [4,12].

Tile drainage systems are not always sufficient to provide suitable moisture conditions in the root zone. These drainage systems then need to be supplemented with additional high-conductivity material by opening the furrows on the tiles or applying mole drainage [13].

### Current studies on mole drainage

Tuohy, et al. [11], investigated the performance of drainage variations during various precipitation event scenarios in a modeling study. A finite element software package was used to model sites with gravel aggregates (10 mm to 50 mm), intersecting mole drains (0.6 m deep, 1.4 m spacing), and underground tile drains (0.9 m deep, 15 m spacing). The soil profile was subjected to a pedological survey of the soil profile in the field and a meteorological station and end-of-pipe flowmeters provided rainfall and discharge data from which the model could be calibrated. The calibrated model showed close agreement between the modeled and observed underground discharge during the validation period.

Aziz, et al. [14], found that soil degradation and low productivity were the main agricultural problems faced by farmers in the newly reclaimed agricultural area in the Nile Delta region of Egypt. They noted that the soils in the area contain high clay and silt and that farmers use traditional mole drainage systems to reduce the salinity of their soil. In their study, they used a combination of natural Spontaneous Potential (SP), apparent Resistivity Gradient (RG), and Electrical Resistivity Tomography (ERT) geo-resistance methods to evaluate mole drains in saline-affected clay soils. Thus, they determined the underground soil structure, the placement of the mole drains and the undisturbed clay layer. They showed that geo-resistance methods, in other words, measurements of the electrical properties of the soil can be used to evaluate subsurface drainage in clay-rich soils.

Singh, et al. [15], used mole drainage and wide bed-grooves (BBF) methods to control surface waterlogging and temporary sub-surface waterlogging in a soybean-wheat growing system in Vertisols in the Madhya Pradesh region of India, over a four-year period from 2016 – 2019. When using the BBF system consisting of 65 m length, 1.50 m spacing, and different depths (15 cm – 25 cm), 29% – 35% in normal and below-normal precipitation conditions (precipitation < 750 mm) and above-normal precipitation (precipitation > 1050 mm) They determined that an increase in soybean crop yield of 14% – 15% was achieved compared to the control. When the 85 mm diameter mole drainage system, which was created at 50 cm depth and 65 m lateral length with 4 m intervals, was used, a 51% increase in soybean yield was achieved in normal and above-normal precipitation conditions compared to the

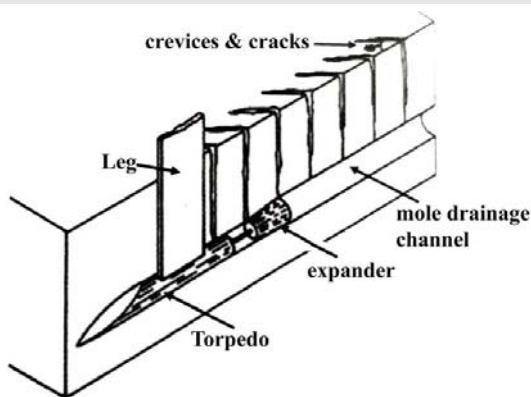

Figure 4: Principle of mole drainage [7].

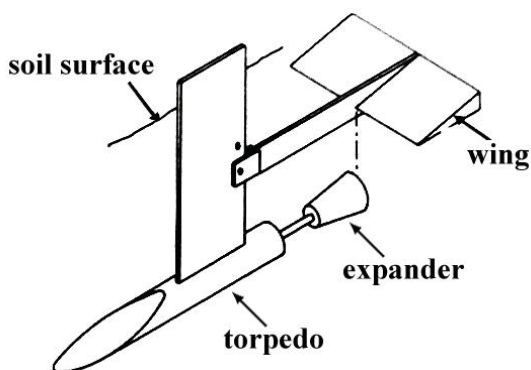

Figure 5: Mole drainage plow with wing [7].

control. The yield of soybean was increased by 66% - 74% in the treatment consisting of MD with BBF under normal rainfall conditions compared to the control. BBF, Mole Drainage, BBF-Mole drainage, and conventional systems were found to be 1.65, 1.99, 2.03 and 0.98 for soybean cultivation using conventional systems, respectively. The payback period of mole drainage technology was found to be less than 2 years. The effect of mole drainage on the next wheat crop was an 11% - 12% increase in yield compared to the control. According to their field studies, they stated that BBF and BBF combined with mole drainage systems are technically feasible and economically viable for the effective drainage of Vertisols.

Nada, et al. [16] conducted a field experiment to examine the effects of mole drainages on saline soil chemical properties and wheat yield in the 2018-2019 and 2019 - 2020 growing seasons at the El-Serw Agricultural Research Station in Egypt. Mole drains were made at a depth of 30 cm - 40 cm with 2 m - 4 m intervals, and two planting methods were applied namely basins and troughs. Their results showed that the increase in the depth of the mole drains and the decrease in the distance between the drains decreased the pH, EC, ESP and OM content and the available N, P and K. The reductions in the furrows planting method were higher than in the basins planting method.

This article was written to provide a new perspective on mole drainage and thus to shed light on future work to improve the method.

## Conclusion

Since the source of raw material for the mole drainage method is the soil itself, making use of this method as much as possible will significantly reduce drainage facility costs. It is necessary to take advantage of these advantages of the method as much as possible while performing drainage works. In addition, environmental pollution created by drainage systems made with pipes made of plastic and similar materials can also be reduced by using the method.

In order to benefit more effectively from mole drainages, parameters such as suitable working width, working depth, and slope must be finely adjusted. For this, alternatives such as GPS and laser positioning systems, which are common technologies today, can be used. Thus, regular and long-lasting drains can be prepared during operation.

Nowadays, electronic cameras, which can be produced in very small sizes, can be moved in the drainage channels and the problems in both mole drains and other drainage system elements can be checked from the inside. Thus, instead of identifying the problematic parts and preparing a completely new system, the existing systems can be maintained longer with minor repairs.

Today, the operation of drainage systems can be monitored by placing wireless sensors, which have been reduced to very small sizes, both in mole drains and piped drainage channels.

Thus, by creating a wireless sensor network structure, the amount of water in the drainage flow can be determined. In addition, salt, lime, nitrate, etc. levels can be seen and parameters such as pH, and EC can also be determined. Thus, a lot of information can be obtained about agricultural land in accordance with the precision agriculture approach. Such data can be used not only for drainage but also for monitoring pesticide and nitrate pollution.

In addition, research should be done in order to apply this method in areas such as loamy soils, sandy soils, stony lands, or similar handicapped areas where the mole drainage method cannot be applied.

## References

1. İşcan S, Ayyıldız Z, Uyan A, Tepeli E, Gökalp Y, Karlı Z, Sarıtaş H, Yaşar M, Çınar M, Çelik A. Problems encountered in irrigation and solutions. Ministry of Agriculture and Rural Affairs Adana Agricultural Production Enterprise and Personnel Training Center Directorate. 2002.
2. Çakır R, Kanber R, Tarı AF. Irrigation and drainage engineering. Ministry of Agriculture and Rural Affairs General Directorate of Rural Services APK Department Soil and Water Resources Research Branch Office. Ankara .2003. 122.
3. Jones LA. Farm drainage. Menemen Regional Irrigated Agriculture Trial Station. 1959; 15.
4. Bahçeci İ. Agricultural drainage systems. Harran University, Faculty of Agriculture, Department of Agricultural Structures and Irrigation. 2017 .
5. Anonymous. Drenler ve drenaj işleri teknik şartnamesi. DSİ. 2014.
6. Öztürk A. Types of closed (pipeline) drainage systems and mole drainage. University of Ankara. 2022, September 15. <https://acikders.ankara.edu.tr/mod/resource/view.php?id=40791> (In Turkish).
7. Dursun İ. Soil tillage tools and machines. Ankara University Printing House, Ankara University Faculty of Agriculture. 2015; 1618.
8. Yılmaz M, Engürülü B, Çiftçi Ö, Gölbaşı M, Başaran HÇ, Akkurt M. Soil tillage tools and machines. Republic of Turkey Ministry of Agriculture and Rural Affairs, Agricultural Production Enterprise, Personnel and Machinery Training Center Directorate, Ankara. 2005.
9. Dinler T, Karaaslan S. Agricultural mechanization-4: Leveling-drainage and irrigation machines. Söke Production Plant Agricultural Technical High School and Mechanization Training Center Directorate. 1982.
10. Kasap Ö, Engürülü B, Çiftçi Ö, Kılınc S, Gölbaşı M, Başaran HÇ, Akkurt M. Agricultural tools and machinery. Ministry of Agriculture and Rural Affairs Ankara Agricultural Production Plant Personnel and Machinery Training Center Directorate, Ankara. 1998.
11. Tuohy P, O'Loughlin J, Fenton O. Modeling performance of a tile drainage system incorporating mole drainage. Transactions of the ASABE. 2018; 61(1):169-178. doi: 10.13031/trans.12203
12. Gemalmaz E. Drain engineering. Atatürk University, Faculty of Agriculture. 1993; 746:317.
13. Filipović V, Mallmann FJK, Coquet Y, Šimunek J. Numerical simulation of water flow in tile and mole drainage systems. Agricultural Water Management. 2014; 146:105-114. doi: 10.1016/j.agwat.2014.07.020
14. Aziz A, Berndtsson R, Attia T, Hamed Y, Selim T. Noninvasive monitoring of subsurface soil conditions to evaluate the efficacy of mole drain in heavy clay soils. Water. 2022; 15(1):110. doi: 10.3390/w15010110



15. Singh R, Rao KR, Singh RK, Singh KP, Singh SK. Drainage technologies for enhancing the productivity of temporary waterlogged vertisols. *Journal of Agricultural Engineering (India)*. 2022; 59(3):279-292. doi: 10.52151/jae2022593.1782

16. Nada WM, Tantawy MF, Hamad MMH, Abo-Elela EG. Integrated effect of mole drains systems and planting methods on saline soil chemical properties and

wheat productivity. *Egyptian Journal of Soil Science*. 2023; 63(2):163-176. doi: 10.21608/EJSS.2023.192612.1571

17. Anonymous. Drainage products. 2023, March 10. <https://rmbuckets.com/drainage-products-and-solutions/>

### Discover a bigger Impact and Visibility of your article publication with Peertechz Publications

#### Highlights

- ❖ Signatory publisher of ORCID
- ❖ Signatory Publisher of DORA (San Francisco Declaration on Research Assessment)
- ❖ Articles archived in worlds' renowned service providers such as Portico, CNKI, AGRIS, TDNet, Base (Bielefeld University Library), CrossRef, Scilit, J-Gate etc.
- ❖ Journals indexed in ICMJE, SHERPA/ROMEO, Google Scholar etc.
- ❖ OAI-PMH (Open Archives Initiative Protocol for Metadata Harvesting)
- ❖ Dedicated Editorial Board for every journal
- ❖ Accurate and rapid peer-review process
- ❖ Increased citations of published articles through promotions
- ❖ Reduced timeline for article publication

**Submit your articles and experience a new surge in publication services**  
(<https://www.peertechz.com/submission>).

*Peertechz journals wishes everlasting success in your every endeavours.*